

ANALOG TEST ENGINES

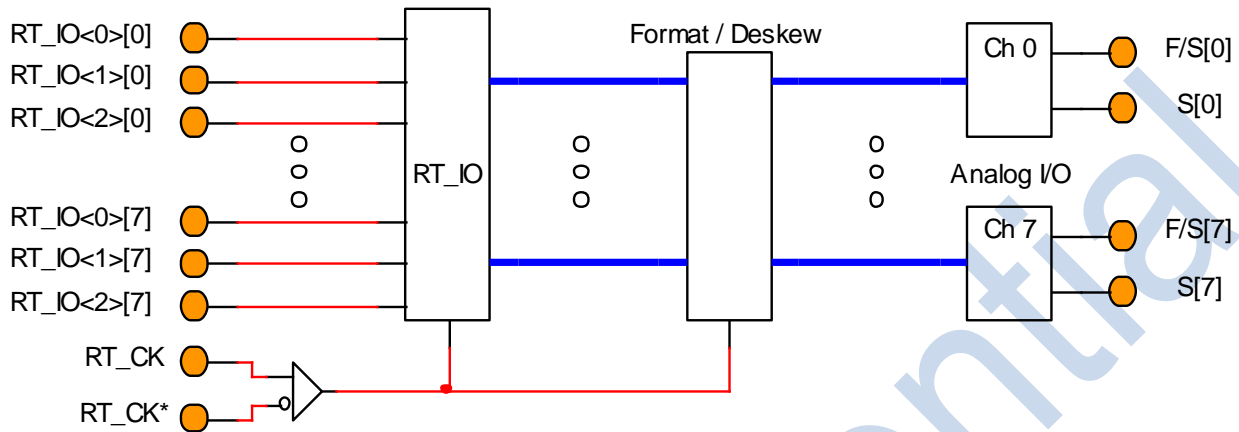

PE105 – Octal, 200 Mb/s, 6V, Pin Electronics / PMU

Pin Electronics – Driver

- 200 Mb/s Fmax
- Programmable Pre-Compensation
- 3 Level Driver w/ on-chip levels
- -0.5V to +5.0V Output Range

Pin Electronics – Comparator

- 200 Mb/s Fmax
- Dual comparator w/ on-chip thresholds
- -2V to +6V Input Range

Real Time Data I/O

- Synchronous / Asynchronous Interface
- Reduced FPGA pin Count Options
 - 1:2 Shift Mode
 - 1:8 Shift Mode

Deskew

- Coarse Delay (625 ps resolution)
- Fine Delay (50 ps resolution)
- Per Channel, Per Function (Drive, Comp)

PMU / V/I

- FV / FI / MV / MI Capability
- -1V to +5.5V I/O Range
- 5 Current Ranges (40.96 mA to 4.096 μ A)
- Programmable Voltage Clamps
- Programmable Current Clamps

Measurement Capability

- MV / MI Capability
- 2 Bit “Go / No Go” Capability
- 2 Independent Analog Monitors (for use with an External ADC)
- 5V Unipolar ADC Interface Option

Built-In Protection

- Over Temperature Protection / Alarm
- Current Clamp Protection / Alarm
- Kelvin Connection Protection
- DUT Ground Continuity Checkers

UTP100 / UTP102 Compatible

2 Pin Serial Port

Power / Package

- 72 Lead, 10 mm X 10 mm QFN
 - Lead Free
 - Exposed Heat Slug on the Bottom
 - Extremely low Θ JC
- 175 mW \leq Pdq / Channel \leq 225 mW

Recommended Applications

- Burn-In Test
- Low-Cost Functional Test
- BIST / Scan Test