

# ANALOG TEST ENGINES

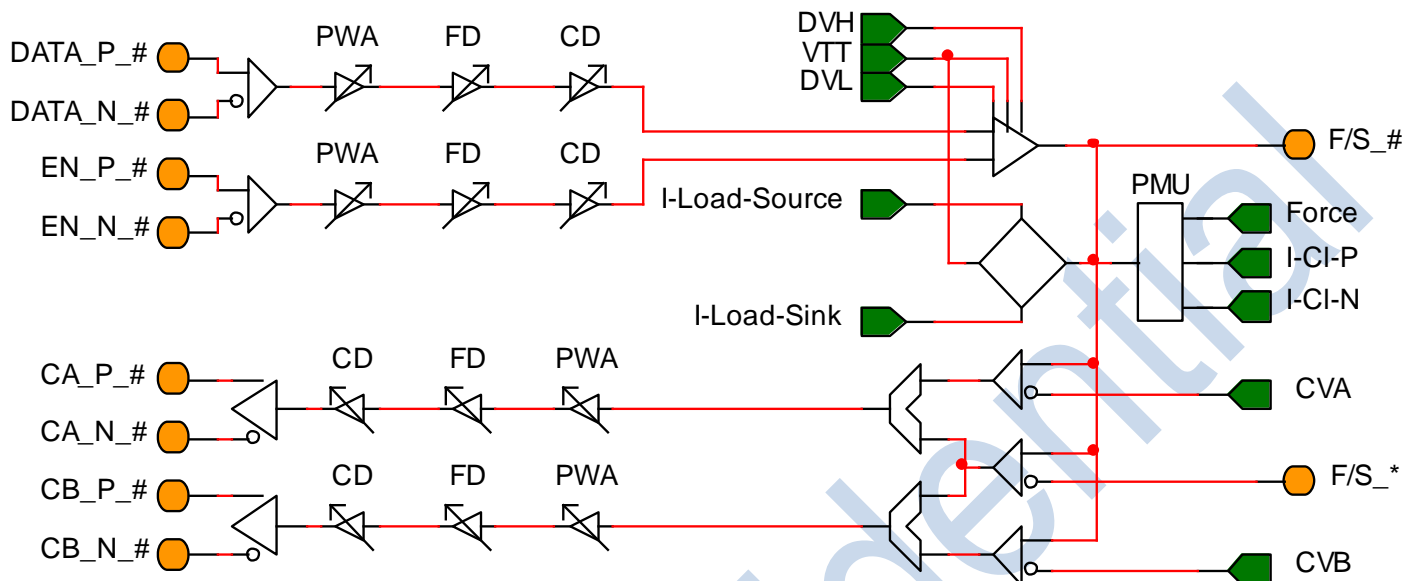

## PE131 – Quad Channel, 5V, 3.2 Gb/s Pin Electronics

### Pin Electronics – Driver

- 3.2 Gb/s Fmax
- 3 Level Driver w/ Constant Rise Time
- -0.5V to +4.0V Output Range
- Programmable Pre-Compensation
- Constant Power vs. Frequency & Pattern

### Pin Electronics – Comparator

- 3.2 Gb/s Fmax
- Dual comparators w/ on-chip thresholds
- Differential comparator
- -1V to +4.5V Input Range
- Differential CML Outputs w/ Programmable Pre-Compensation
- 4.0 Gb/s High Frequency Pre-Scalar

### Deskew

- Coarse Delay (1.26 ns range, 20 ps res)
- Fine Delay
  - Adjustable span from 500 ps to 2.5 ns
  - Resolution from 0.5 ps to 2.5 ps
- Pulse Width Adjust ( $\pm 127$  ps / 1 ps Res)

### Active Load

- 24 mA / Split Load
- Independent Source and Sink Currents

### 2 Pin Serial Port

### PMU

- FV / FI / MV / MI Capability
- -1.0V to +4.5V FV Range
- -1.0V to +5.0V MV Range
- 5 Current Ranges (4.096  $\mu$ A to 40.96 mA)
- Programmable Voltage / Current Clamps
- Current Load Compensation

### Measurement Capability

- MV / MI Capability
- +5V ADC Interface Option
- External Force / Sense Switches
- Monitor (with an External ADC)

### Built-In Self Protection

- Over Temperature Alarm
- Current / Voltage Clamp Alarm
- DUT Ground Continuity Checker

### FPGA Real Time Interface

- Differential CML w/ On-Chip Terminations
- Asynchronous (1:1 or 1:4 Fanout)

### Package / Power

- 10 mm X 10 mm QFN, Lead Free
- Exposed heat slug on bottom
- 72 Lead, 0.5 mm lead pitch
- 750 mW to 1.5 Watt / Channel (Pd<sub>q</sub>)