

ANALOG TEST ENGINES

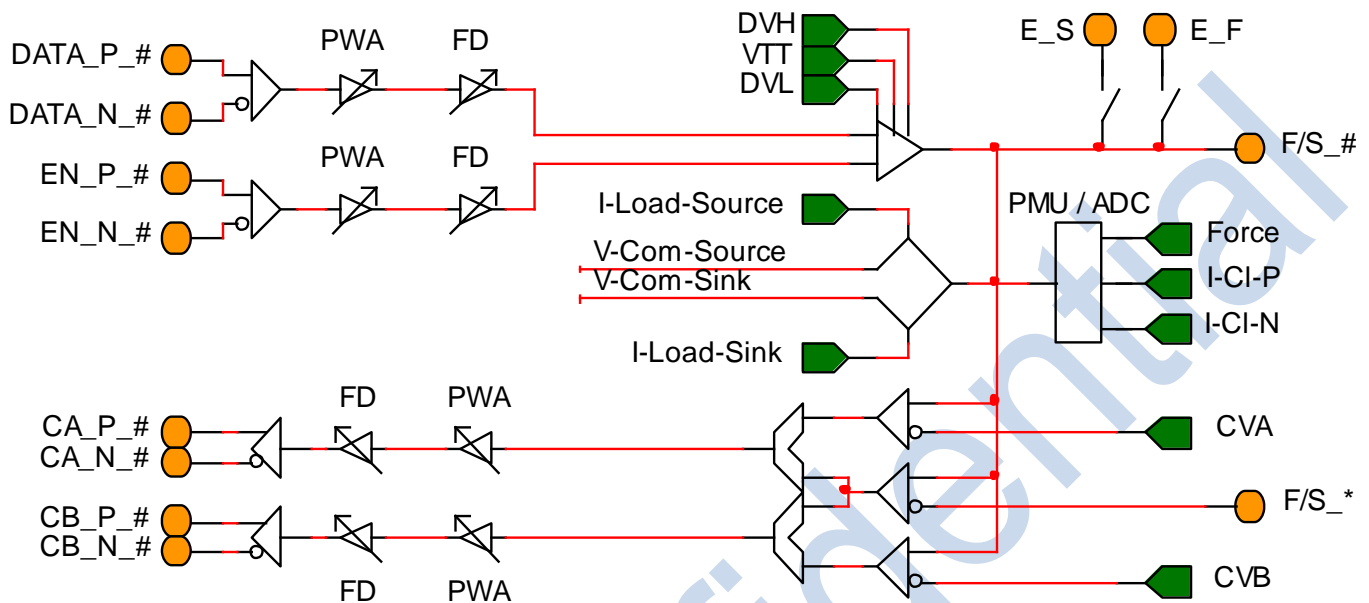

PE180 – Quad Channel, 7V, 2.0 Gb/s, Pin Electronics

Pin Electronics – Driver

- 2.0 Gb/s Fmax
- 3 Level Driver
- -1.5V to +4.5V Output Range

Pin Electronics – Comparator

- 2.0 Gb/s Fmax
- -2.0V to +5.0V Input Range
- Dual comparators w/ on-chip thresholds
- Differential Comparator
- Central AC Calibration Comparator

Deskew

- Fine Delay
 - Adjustable span from 400 ps to 5.0 ns
 - Resolution from 0.4 ps to 5 ps
- Pulse Width Adjust (± 200 ps / 1.5 ps Res)

Active Load

- 24 mA I_{max}
- Split Load
- Independent Source and Sink Currents

FPGA Real Time Interface

- Differential CML Inputs / Outputs
- Asynchronous (1:1 or 1:4 Fanout)

PMU

- FV / FI / MV / MI Capability
- -2.0V to +5.5V Voltage Range
- 5 Current Ranges (50 mA to 5 μ A)
- Programmable Voltage / Current Clamps
- DUT Ground Continuity Checker
- Remote Sense Option

Measurement Capability

- Integrated 16-Bit ADC
- MV / MI Capability
- External Force / Sense Switches
- Monitor (with an External ADC)

Built-In Self Protection

- Over Temperature Alarm
- Current / Voltage Clamp Alarm

2 Pin Serial Port

Package / Power

- 10 mm X 10 mm QFN, Lead Free
- Exposed heat slug on bottom
- 72 Lead, 0.5 mm lead pitch
- 1.2W / Channel (No Load)