

ANALOG TEST ENGINES

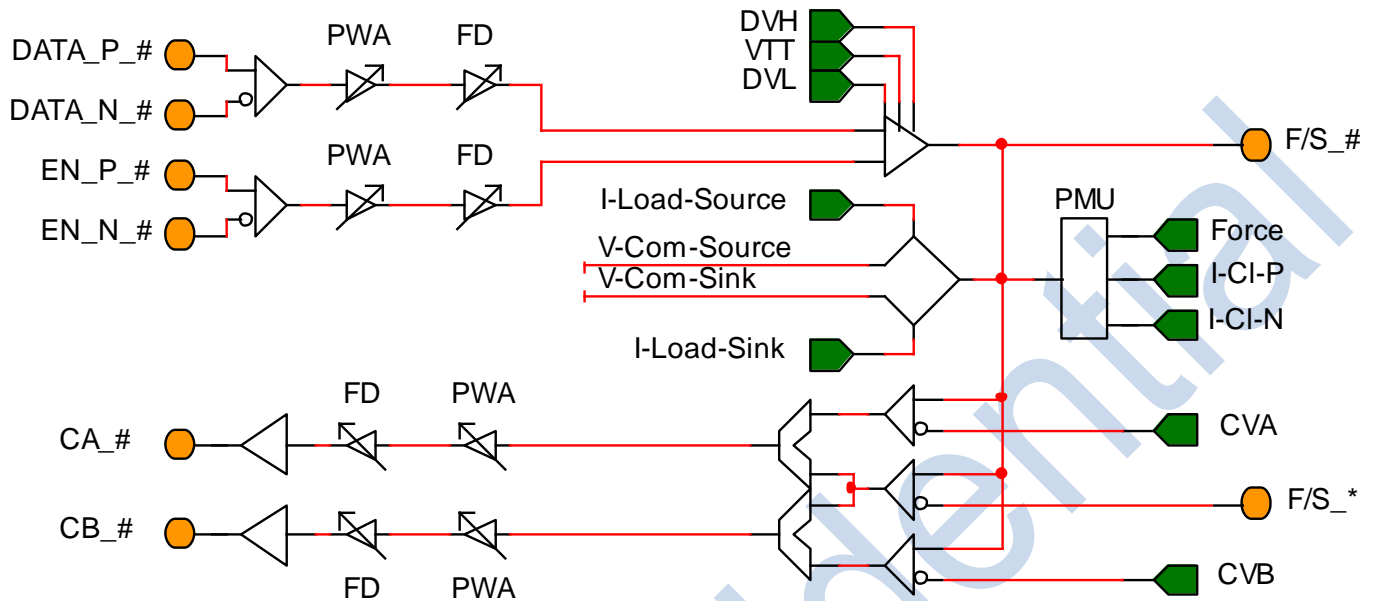

PE230 – Quad Channel, 9V, 800 Mb/s, Pin Electronics

Pin Electronics – Driver

- 800 Mb/s Fmax
- 3 Level Driver
- -2.0V to +7.0V Output Range
- Programmable Slew Rate (0.1 V/ns to 1.8 V/ns)

Pin Electronics – Comparator

- 800 Mb/s Fmax
- Dual comparators w/ on-chip thresholds
- Differential comparator
- -2V to +7V Input Range
- High Frequency Prescaler
- Adjustable Comparator Output Swings

Deskew

- Fine Delay
 - Adjustable span from 1 ns to 10 ns
 - Resolution from 1 ps to 10 ps
- Pulse Width Adjust (± 512 ps / 4 ps Res)

Active Load

- 24 mA I_{max}
- Split Load
- Independent Source and Sink Currents

2 Pin Serial Port

FPGA Real Time Interface

- Differential CML Inputs / 1.8V CMOS
- Asynchronous (1:1 or 1:4 Fanout)
- Single-Ended CMOS Outputs

PMU

- FV / FI / MV / MI Capability
- -2.0V to +7V Voltage Range
- 5 Current Ranges (50 mA to 5 μ A)
- Programmable Voltage / Current Clamps
- DUT Ground Continuity Checker

Measurement Capability

- MV / MI Capability
- External Force / Sense Switches
- Monitor (with an External ADC)
- ± 2.5 V ADC Interface Option

Built In Self Protection

- Over Temperature Alarm
- Current / Voltage Clamp Alarm

Package / Power

- 10 mm X 10 mm QFN, RoHS Compliant
- Exposed heat slug on bottom
- 72 Lead, 0.5 mm lead pitch
- 250 mW to 1W / Channel (Pd_q)