

ANALOG TEST ENGINES

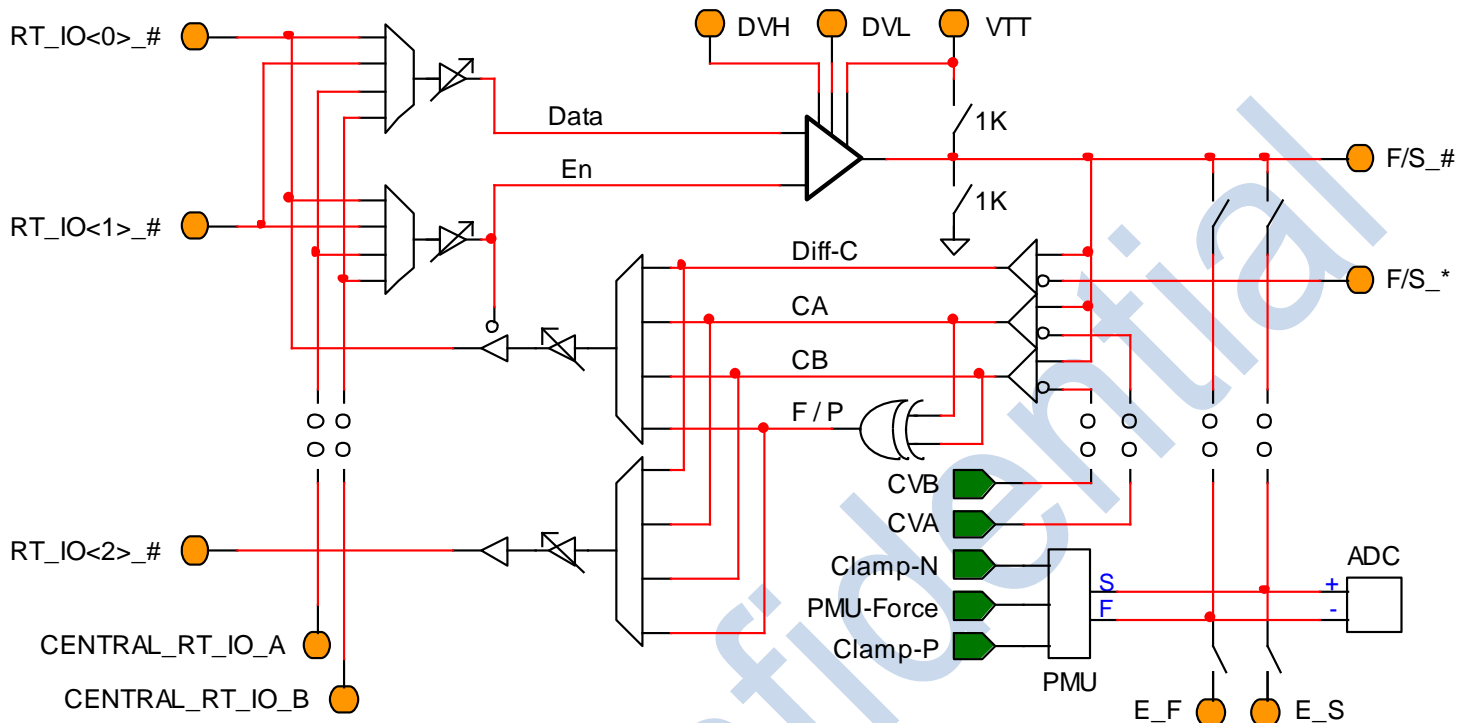

PE70 – 8 Channel, 5V, 1 Gb/s Pin Electronics

Pin Electronics – Driver

- 1 Gb/s, 3 Level Driver, Differential Driver
- -1.0V to +5.0V Output Range
- 1K Ω HiZ Pull-Up / Pull-Down Options
- Differential Driver Configuration Option

Pin Electronics – Comparator

- 1 Gb/s Fmax
- -2.0V to +5.0V Input Range
- Dual comparators w/ on-chip thresholds
- Differential comparator per channel-pair
- Pass / Fail Mode

Deskew

- Coarse Delay (5 ns range, 40 ps res)
- Pulse Width Adjust (± 256 ps / 4 ps Res)

FPGA Real Time Interface

- Flexible FPGA Interface
- 2 or 3 FPGA Pins / Channel
- 2 Central FPGA Pins / Chip
- CMOS I/O w/ On-Chip Terminations
- Technology Independent (Adjustable) I/O

PMU

- 1 PMU / Chip
- -1.0 to +4.0V Measure Range
- -0.75 to +4.0V Force Range
- 5 Current Ranges (4 μ A to 40 mA)
- FV / FI / MV / MI
- Voltage / Current Clamps
- F/S_# Continuity Checker
- DUT Ground Continuity Checker

Measurement System

- Integrated 16-Bit ADC
- Integrated Force & Sense Switches

Built-In Self Protection

- Over Temperature Alarm

Package / Power

- 10 mm X 10 mm QFN, Lead Free
- Exposed heat slug on bottom
- 72 Lead, 0.5 mm lead pitch
- 75 to 175 mW / Channel (Pd_q)