

ANALOG TEST ENGINES

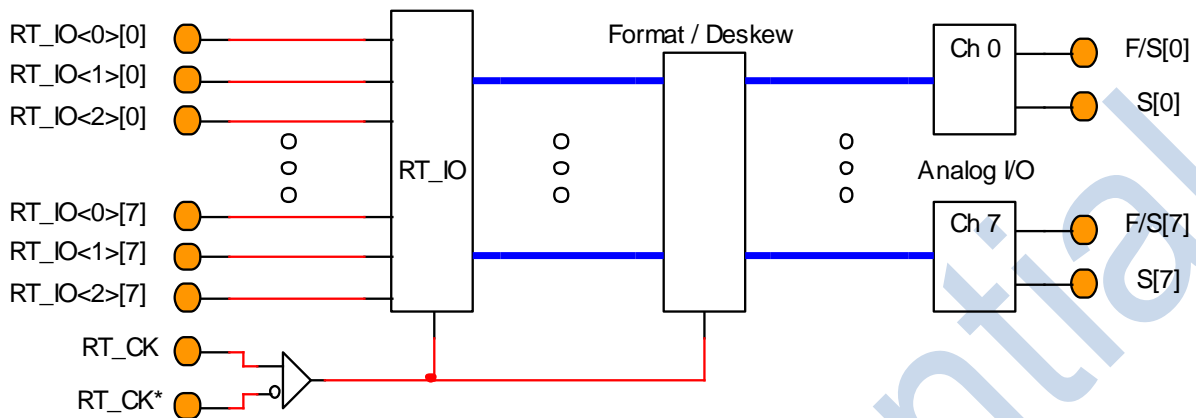

UTP102 – Octal, 200 Mb/s, 6V, 400 mA Universal Test Pin

Pin Electronics – Driver

- 50Ω / 5Ω Options
- 200 Mb/s Fmax
- Programmable Pre-Compensation
- 3 Level Driver w/ on-chip levels
- -1V to +5.0V Output Range

Pin Electronics – Comparator

- 200 Mb/s Fmax
- Dual comparator w/ on-chip thresholds
- -1V to +5V Input Range

Real Time Data I/O

- Synchronous / Asynchronous Interface
- Reduced FPGA pin Count Options
 - 1:2 Shift Mode
 - 1:8 Shift Mode

Deskew

- Coarse Delay (625 ps resolution)
- Fine Delay (50 ps resolution)

DPS / PMU / V/I

- FV / FI / MV / MI Capability
- -1V to +5.0V I/O PMU Range
- 0V to +4.0V I/O DPS Range
- 6 Current Ranges (409.6 mA to 4.096 μA)
- Programmable Voltage / Current Clamps
- Ganging Capability
- Power Amplifier Controller Mode
 - High Voltage Operation
 - High Current Operation

Measurement Capability

- MV / MI Capability
- 2 Bit “Go / No Go” Capability
- 2 Independent Analog Monitors (for use with an External ADC)
- 5V Unipolar ADC Interface Option

Built In Protection

- Over Temperature Protection / Alarm
- Over Current Protection / Alarm
- Current Clamp Protection / Alarm
- Kelvin Connection Protection
- DUT Ground Continuity Checkers

UTP100 Compatible

2 Pin Serial Port

Power / Package

- 72 Lead, 10 mm X 10 mm QFN
 - Lead Free
 - Exposed Heat Slug on the Bottom
 - Extremely low ΘJC
- 100 mW ≤ Pdq / Channel ≤ 300 mW
- Separate DPS Positive Power Supply

Recommended Applications

- Burn-In Test
- Low-Cost Functional Test
- BIST / Scan Test
- In-Circuit PCB Test